

Fiberglass Crossarms

The support you need from the name you trust

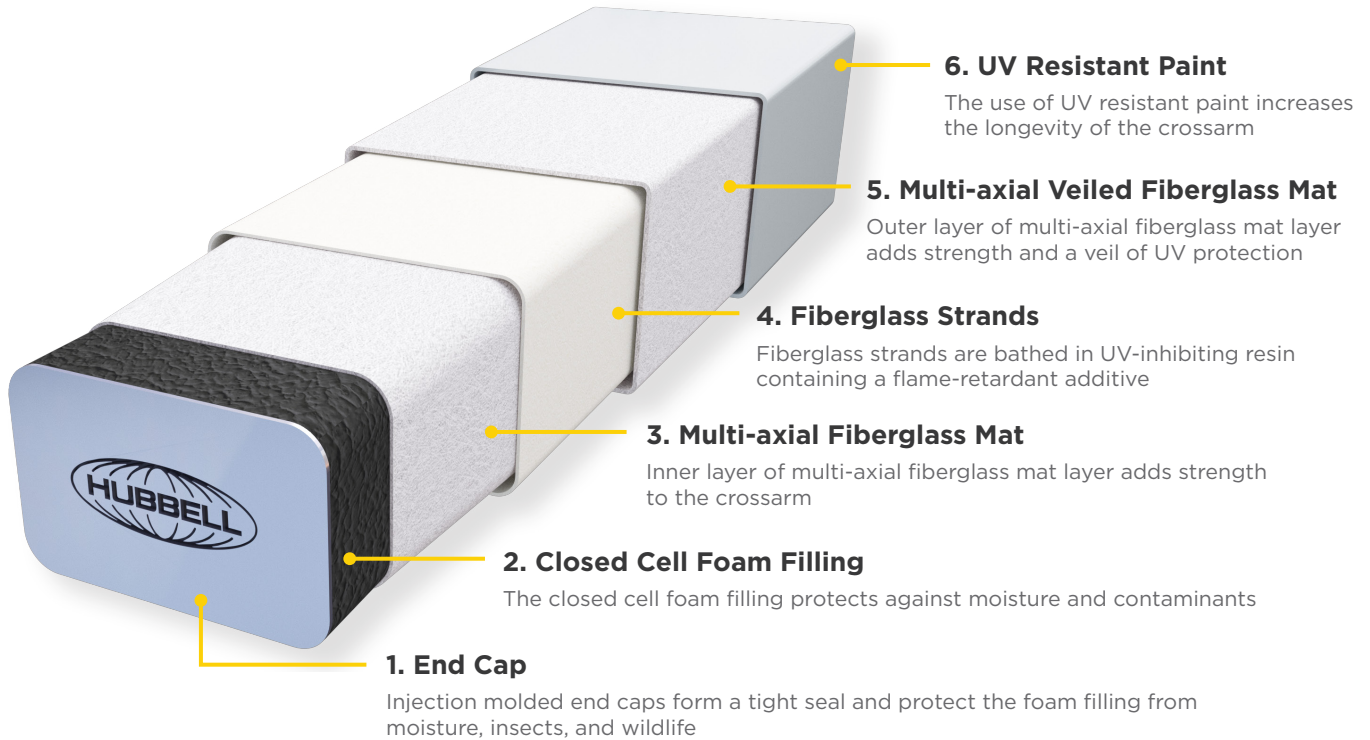

Durable

Expect long-lasting performance with fiberglass crossarms that resist UV degradation, fire, rot, and insect damage.



Easy to Install

Simplify installation with lightweight composite crossarms that feature a center-mounted, brace-less design.



Multiple Styles

Choose from tangent and deadend styles in various standard lengths as well as custom sizes for your specific application.



Adaptable

The mounting bracket has multiple size bolt holes and a keyhole slot. Deadend styles also include double guy-mounting holes.



Hubbell Advantage

Manufactured in-house at our Centralia, Missouri facility using a tried-and-true pultrusion process and strength tested for quality assurance. Freight consolidation is available for customers ordering multiple Hubbell products.



Strong

Welded construction and a galvanized mounting bracket offer solid foundational support, and a stamped steel galvanized square washer design helps evenly distribute the load.

Fiberglass Crossarms



Tangent Style Crossarm



Deadend Style Crossarm

Tangent Load Capacity Comparison Per Wire

No. of Wires	Length	Tangent 22	Tangent 20	Tangent 25	Tangent 30
4-Wire	96"	2,250 LBS	3,500 LBS	3,500 LBS	5,000 LBS
6-Wire	96"	1,500 LBS	2,250 LBS	2,250 LBS	3,250 LBS
4-Wire	120"	2,250 LBS	3,375 LBS	3,500 LBS	5,000 LBS
6-Wire	120"	1,500 LBS	2,250 LBS	2,250 LBS	3,250 LBS
4-Wire	144"	N/A	3,250 LBS	3,500 LBS	5,000 LBS
6-Wire	144"	N/A	2,150 LBS	2,250 LBS	3,250 LBS

Deadend Load Capacity Comparison Per Wire

No. of Wires	Length	Deadend 20	Deadend 25
2-Wire	96"	7,500 LBS	8,125 LBS
3-Wire	96"	7,500 LBS	8,125 LBS
4-Wire	96"	5,500 LBS	6,000 LBS
2-Wire	120"	7,500 LBS	8,100 LBS
4-Wire	120"	5,500 LBS	6,000 LBS
2-Wire	144"	N/A	6,525 LBS
4-Wire	144"	N/A	4,500 LBS

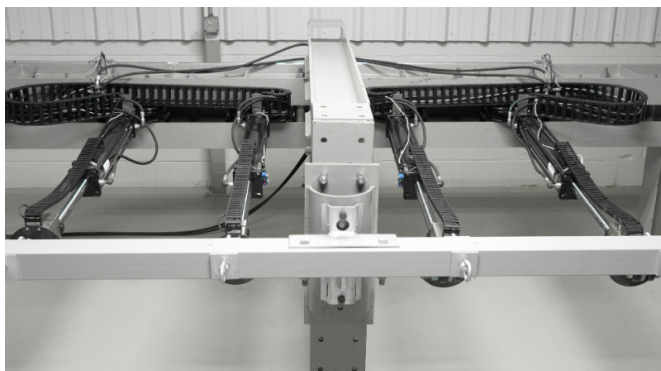

4- point balanced load testing cell located in Centralia, MO

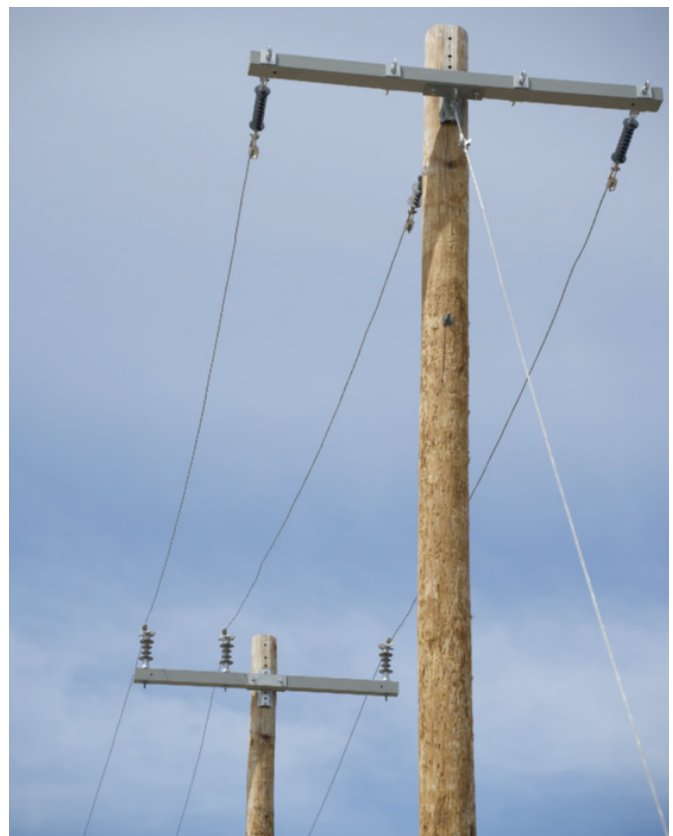

Smart Part Numbering System

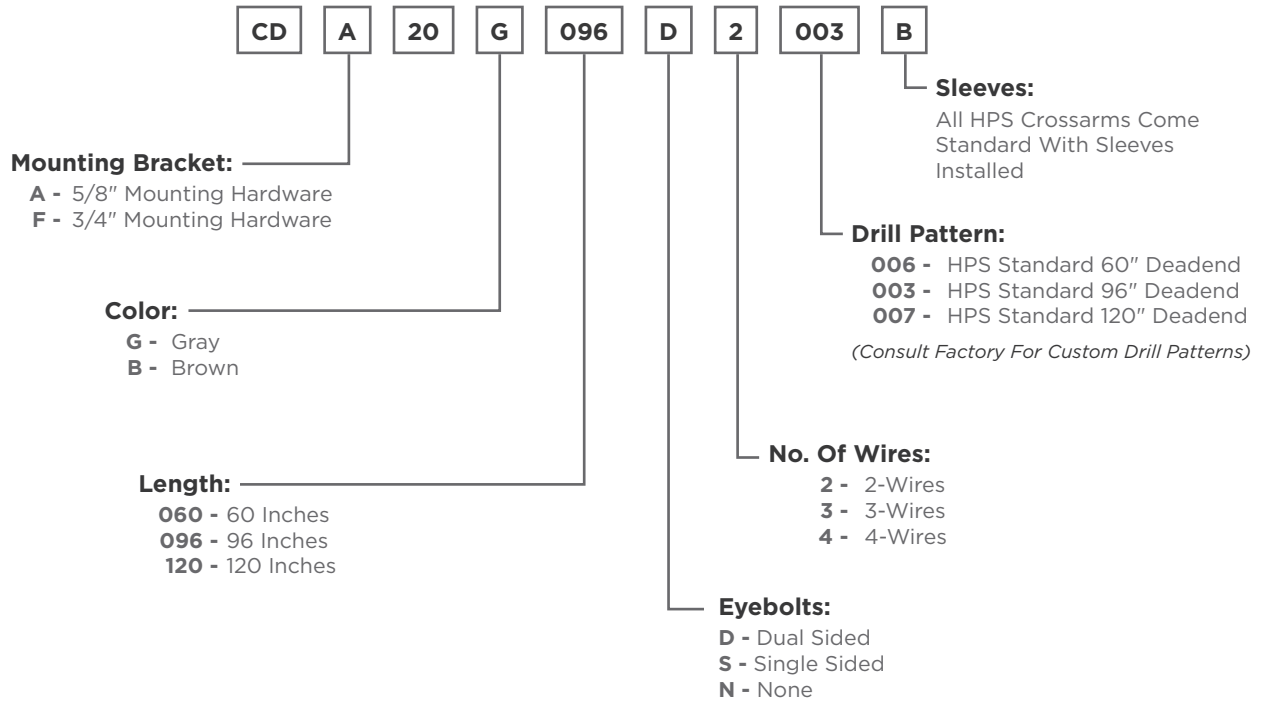

Series 20 Deadend

Catalog Number	Length	No. of Wires	Minimum Ultimate Longitudinal Load per wire	Mounting Bracket Hardware	Total Assembly Weight (Each)	Color	Drill Pattern	Eye Nuts
CDA20G060D2006B	60" (5')	2	13,125 lbs.	5/8"	45.9 lbs.	Gray	006	Dual Sided
CDA20G096D2003B	96" (8')	2	7,500 lbs.	5/8"	56.4 lbs.	Gray	003	Dual Sided
CDA20G096D3003B	96" (8')	3	7,500 lbs.	5/8"	60.6 lbs.	Gray	003	Dual Sided
CDA20G096D4003B	96" (8')	4	5,500 lbs.	5/8"	64.8 lbs.	Gray	003	Dual Sided
CDA20G120D2007B	120" (10')	2	7,500 lbs.	5/8"	63.4 lbs.	Gray	007	Dual Sided
CDA20G120D4007B	120" (10')	4	5,500 lbs.	5/8"	71.8 lbs.	Gray	007	Dual Sided

Fiberglass Series 20 Deadends

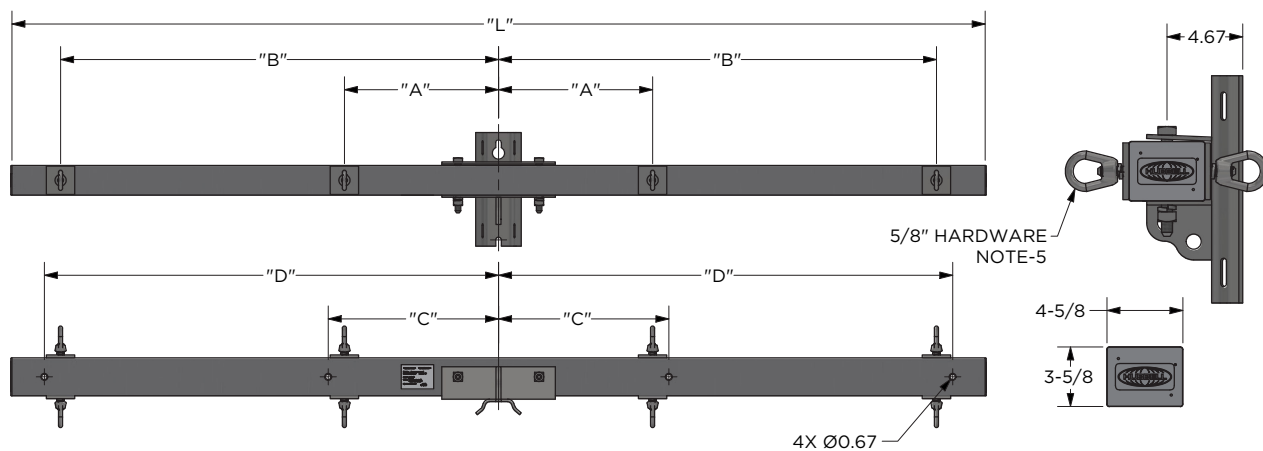

- MATERIAL: Arm:** Fiberglass tube filled with closed cell foam mounting bracket & **Hardware:** Galvanized steel
- COLOR:** Gray (brown optional) painted with UV inhibitor paint
- 5/8" hardware includes 8" DA bolt, custom washer, lockwasher, and eye nut
- All crossarm holes come standard with sleeves installed
- RECOMMENDED HARDWARE TORQUE:** 250 in-lbs
- HOLES AVAILABLE IN OPTIONAL SIZES DEPENDING ON CATALOG NUMBER:**
 "CDA": 5/8" hardware
 "CDF": 3/4" hardware
- Two hole guy attachment for 7/8" guying hardware. Ultimate guy load 30,000 lbs per attachment.
- For a complete list of options see Smart Numbering System

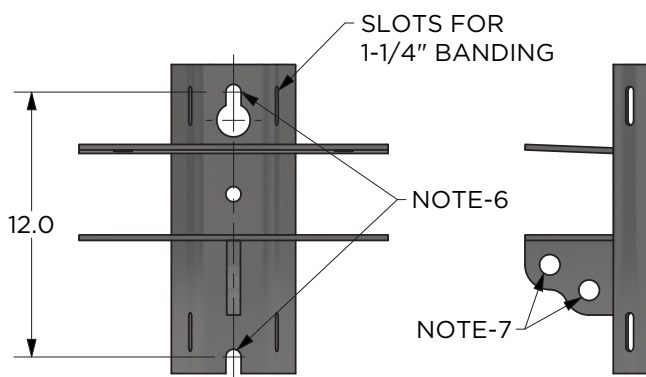

Catalog Number (Note 8)	"L"	"A"	"B"	"C"	"D"	NO. OF WIRES	ULTIMATE RATING (PER WIRE)
CDA20G060D2006B	60"	N/A	24"	17"	26"	2	13,125 LBS
CDA20G096D2003B	96"	N/A	42"	17"	44"	2	7,500 LBS
CDA20G096D3003B	96"	N/A	42"	17"	44"	3	7,500 LBS
CDA20G096D4003B	96"	15"	42"	17"	44"	4	5,500 LBS
CDA20G120D2007B	120"	N/A	54"	21"	56"	2	7,500 LBS
CDA20G120D4007B	120"	19"	54"	21"	56"	4	5,500 LBS

Smart Part Numbering System

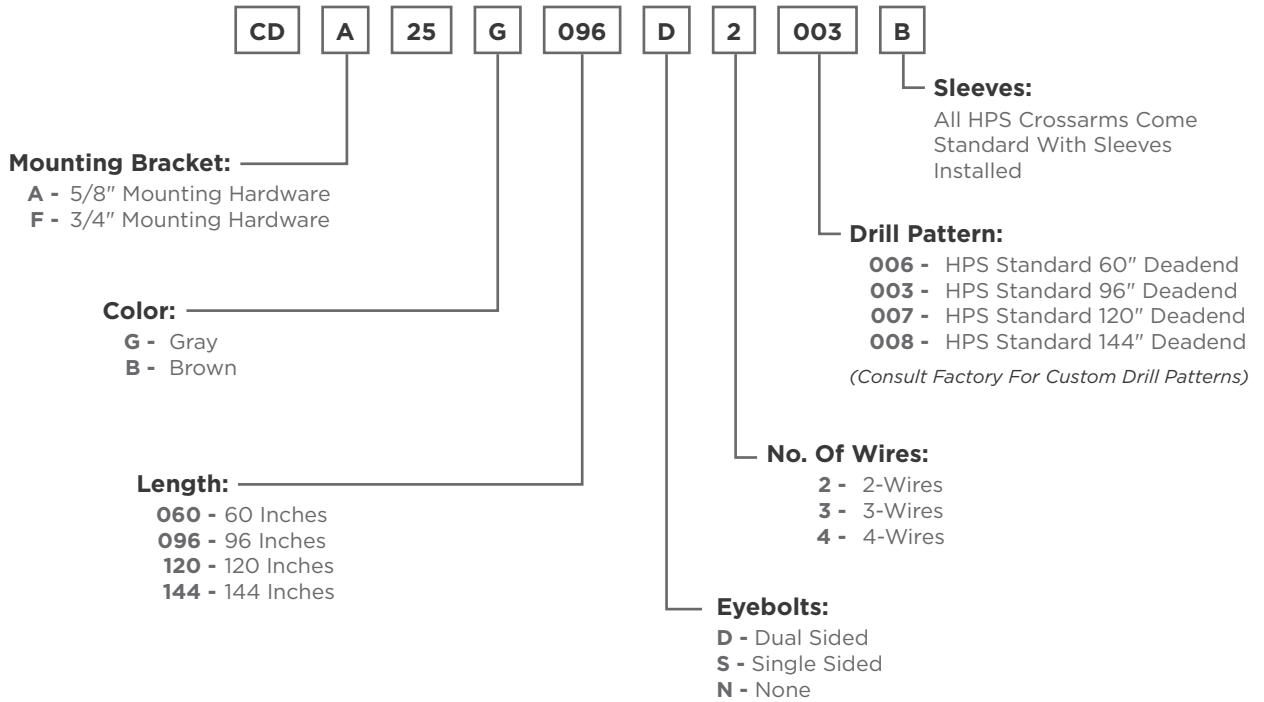

Series 25 Deadend

Catalog Number	Length	No. of Wires	Minimum Ultimate Longitudinal Load per wire	Mounting Bracket Hardware	Total Assembly Weight (Each)	Color	Drill Pattern	Eye Nuts
CDA25G060D2003B	60" (5')	2	14,200 lbs.	5/8"	48.4 lbs.	Gray	003	Dual Sided
CDA25G096D2003B	96" (8')	2	8,125 lbs.	5/8"	60.4 lbs.	Gray	003	Dual Sided
CDA25G096D3003B	96" (8')	3	8,125 lbs.	5/8"	64.6 lbs.	Gray	003	Dual Sided
CDA25G096D4003B	96" (8')	4	6,000 lbs.	5/8"	68.8 lbs.	Gray	003	Dual Sided
CDA25G120D4007B	120" (10')	2	8,100 lbs.	5/8"	68.4 lbs.	Gray	007	Dual Sided
CDA25G120D4007B	120" (10')	4	6,000 lbs.	5/8"	76.8 lbs.	Gray	007	Dual Sided
CDA25G144D2008B	144" (12')	2	6,525 lbs.	5/8"	76.4 lbs.	Gray	007	Dual Sided
CDA25G144D4008B	144" (12')	4	4,500 lbs.	5/8"	84.8 lbs.	Gray	007	Dual Sided

Fiberglass Series 25 Deadends

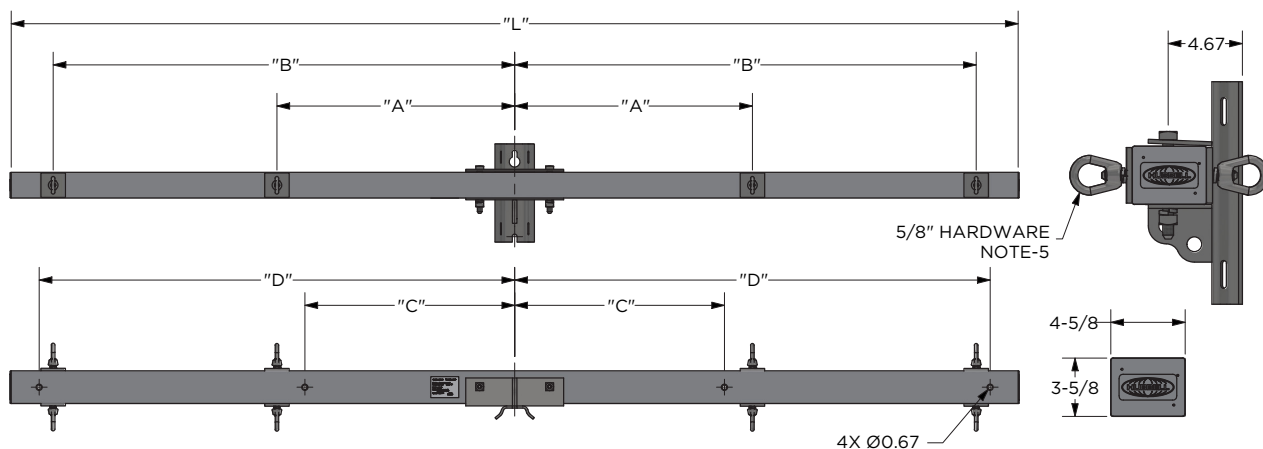

- MATERIAL: Arm:** Fiberglass tube filled with closed cell foam mounting bracket & **Hardware:** Galvanized steel
- COLOR:** Gray (brown optional) painted with UV inhibitor paint
- 5/8" hardware includes 8" DA bolt, custom washer, lockwasher, and eye nut
- All crossarm holes come standard with sleeves installed
- RECOMMENDED HARDWARE TORQUE:** 250 in-lbs
- HOLES AVAILABLE IN OPTIONAL SIZES DEPENDING ON CATALOG NUMBER:**
 "CDA": 5/8" hardware
 "CDF": 3/4" hardware
- Two hole guy attachment for 7/8" guying hardware. Ultimate guy load 30,000 lbs per attachment.
- For a complete list of options see Smart Numbering System

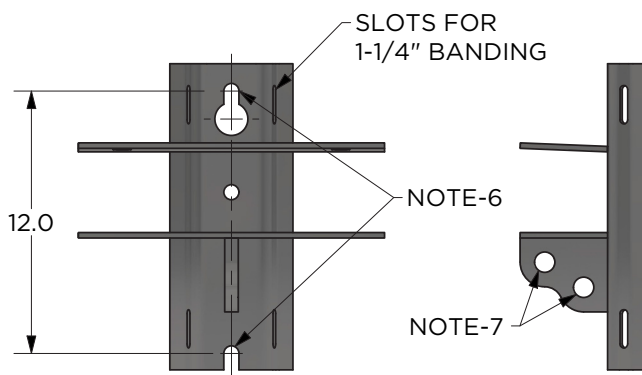

Catalog Number (Note 8)	"L"	"A"	"B"	"C"	"D"	NO. OF WIRES	ULTIMATE RATING (PER WIRE)
CDA25G060D2006B	60"	N/A	24"	17"	26"	2	14,200 LBS
CDA25G096D2003B	96"	N/A	42"	17"	44"	2	8,125 LBS
CDA25G096D3003B	96"	N/A	42"	17"	44"	3	8,125 LBS
CDA25G096D4003B	96"	15"	42"	17"	44"	4	6,000 LBS
CDA25G120D2007B	120"	N/A	54"	21"	56"	2	8,100 LBS
CDA25G120D4007B	120"	19"	54"	21"	56"	4	6,000 LBS
CDA25G144D2008B	144"	N/A	66"	30"	68"	2	6,525 LBS
CDA25G144D4008B	144"	34"	66"	30"	68"	4	4,500 LBS

Smart Part Numbering System

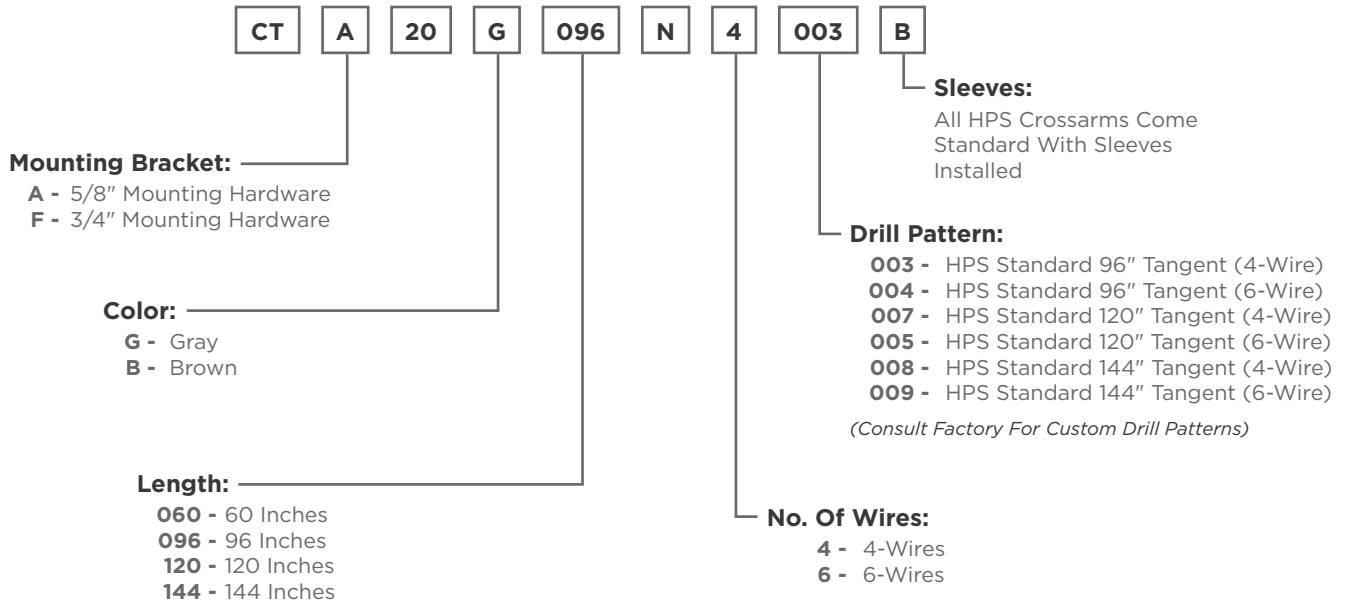

Series 20 Tangent

Catalog Number	Length	No. of Wires	Minimum Ultimate Longitudinal Load per wire	Mounting Bracket Hardware	Total Assembly Weight (Each)	Color	Drill Pattern
CTA20G096N4003B	96" (8')	4	3,500 lbs.	5/8"	51 lbs.	Gray	003
CTA20G096N6004B	96" (8')	6	2,250 lbs.	5/8"	51 lbs.	Gray	004
CTA20G120N4007B	120" (10')	4	3,375 lbs.	5/8"	58 lbs.	Gray	007
CTA20G120N6005B	120" (10')	6	2,250 lbs.	5/8"	58 lbs.	Gray	005
CTA20G144N4008B	144" (12')	4	3,250 lbs.	5/8"	65 lbs.	Gray	008
CTA20G144N6009B	144" (12')	6	2,150 lbs.	5/8"	65 lbs.	Gray	009

Fiberglass Series 20 Tangent

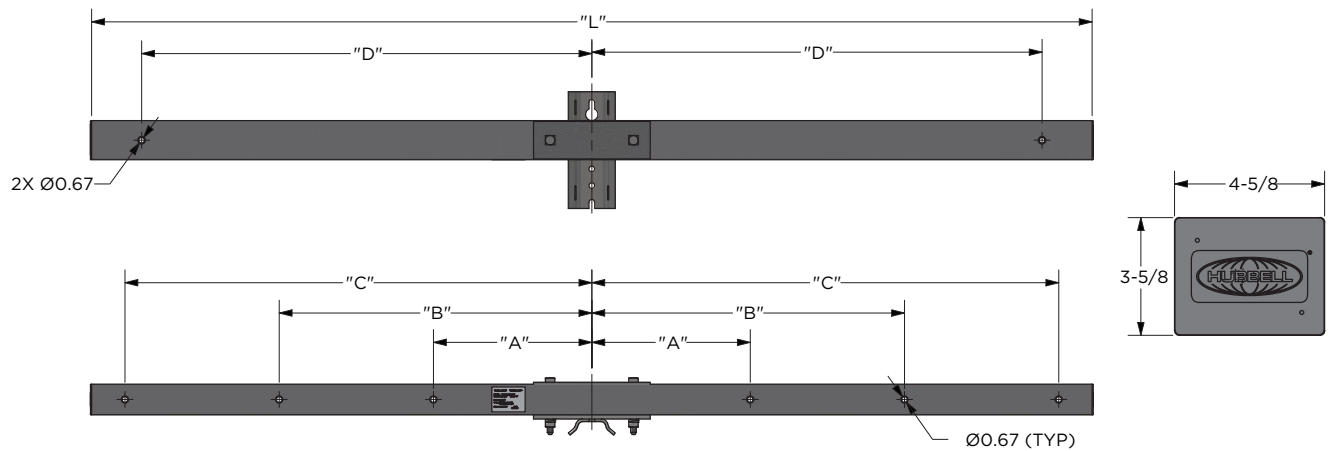

- MATERIAL: Arm:** Fiberglass tube filled with closed cell foam mounting bracket & **Hardware:** Galvanized steel
- COLOR:** Gray (brown optional) painted with UV inhibitor paint
- All crossarm holes come standard with sleeves installed
- RECOMMENDED HARDWARE TORQUE:** 250 in-lbs
- HOLES AVAILABLE IN OPTIONAL SIZES DEPENDING ON CATALOG NUMBER:**
 "CDA": 5/8" hardware
 "CDF": 3/4" hardware
- For a complete list of options see Smart Numbering System

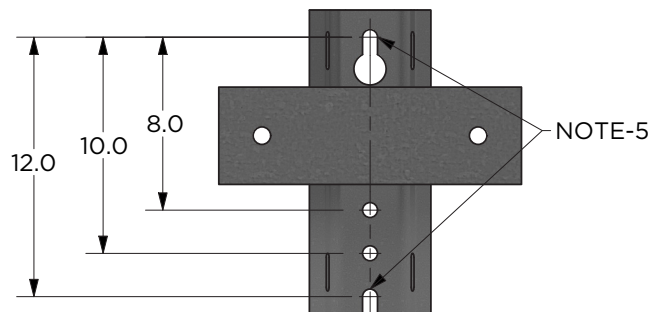

Catalog Number (Note 8)	RUS DRILL PATTERN	"L"	"A"	"B"	"C"	"D"	NO. OF WIRES	ULTIMATE RATING (PER WIRE)
CTA20G096N4003B	003	96"	15"	N/A	44"	42"	4	3,500 LBS
CTA20G096N6004B	004	96"	15"	29.5"	44"	42"	6	2,250 LBS
CTA20G120N4007B	N/A	120"	19"	N/A	56"	54"	4	3,375 LBS
CTA20G120N6005B	005	120"	19"	37.5"	56"	54"	6	2,250 LBS
CTA20G144N4008B	N/A	144"	38"	N/A	66"	68"	4	3,250 LBS
CTA20G144N4009B	N/A	144"	38"	53"	66"	68"	6	2,150 LBS

Fiberglass Series 22 Tangent

Smart Part Numbering System

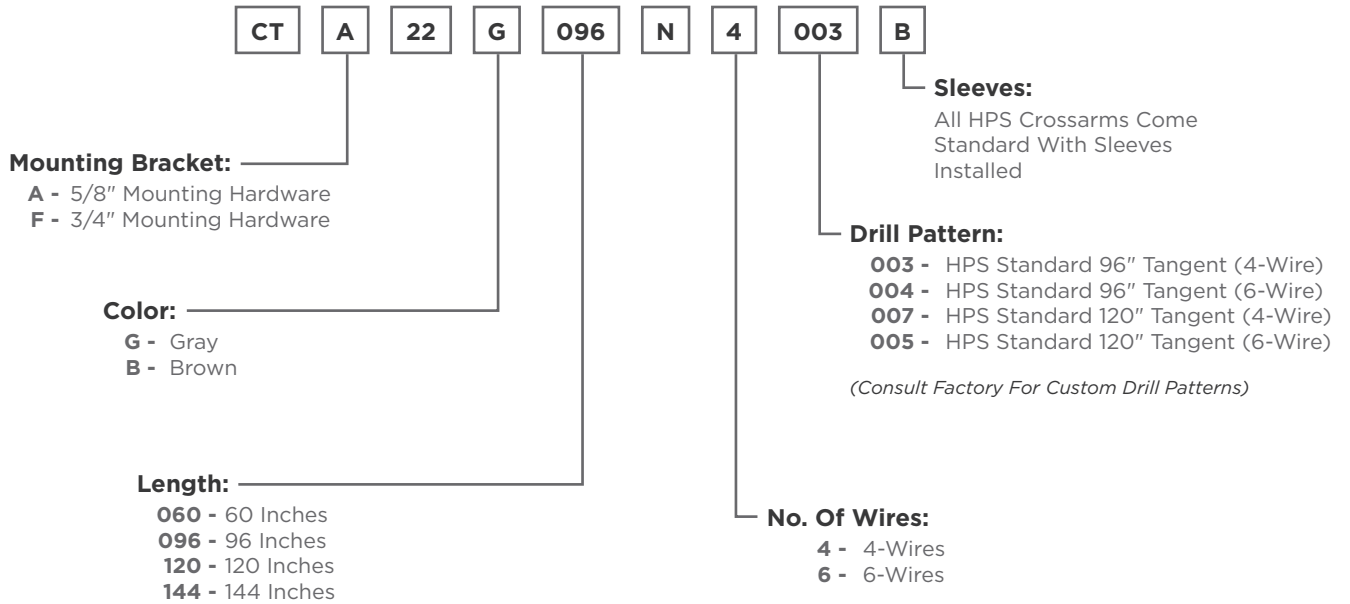

Series 22 Tangent

Catalog Number	Length	No. of Wires	Minimum Ultimate Longitudinal Load per wire	Mounting Bracket Hardware	Total Assembly Weight (Each)	Color	Drill Pattern
CTA22G096N4003B	96" (8')	4	2,250 lbs.	5/8"	43 lbs.	Gray	003
CTA22G096N6004B	96" (8')	6	1,500 lbs.	5/8"	43 lbs.	Gray	004
CTA22G120N4007B	120" (10')	4	2,250 lbs.	5/8"	50 lbs.	Gray	007
CTA22G120N6005B	120" (10')	6	1,500 lbs.	5/8"	50 lbs.	Gray	005

Fiberglass Series 22 Tangent

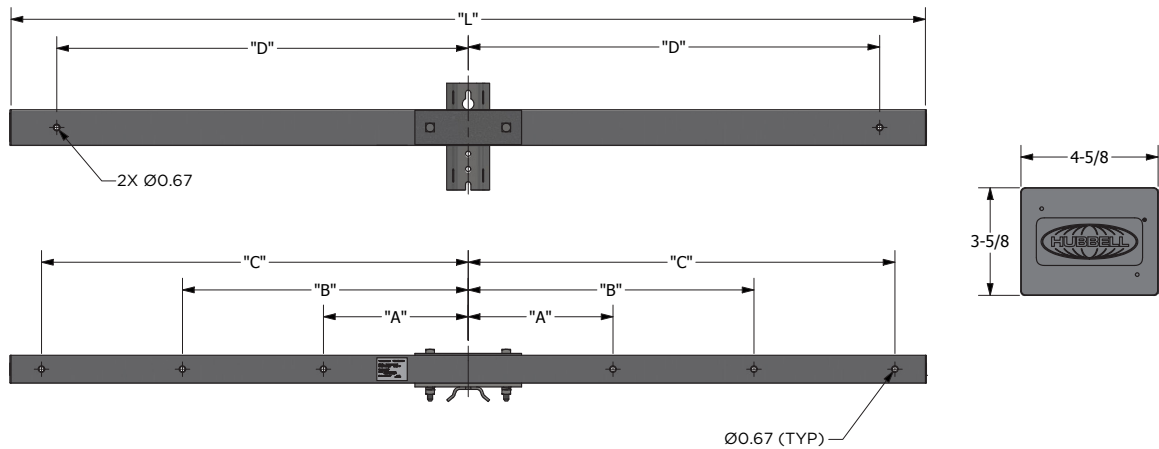

- MATERIAL: Arm:** Fiberglass tube filled with closed cell foam mounting bracket & **Hardware:** Galvanized steel
- COLOR:** Gray (brown optional) painted with UV inhibitor paint
- All crossarm holes come standard with sleeves installed
- RECOMMENDED HARDWARE TORQUE:** 250 in-lbs
- HOLES AVAILABLE IN OPTIONAL SIZES DEPENDING ON CATALOG NUMBER:**
 "CDA": 5/8" hardware
 "CDF": 3/4" hardware
- For a complete list of options see Smart Numbering System

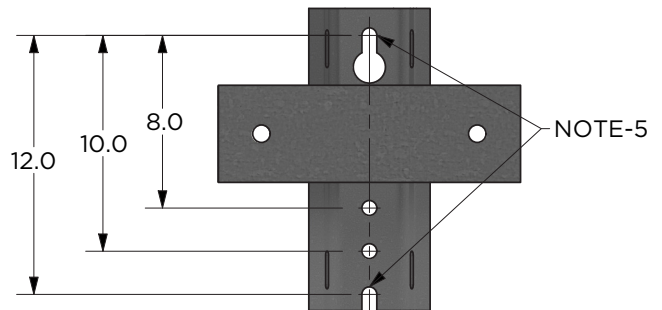

Catalog Number (Note 8)	RUS DRILL PATTERN	"L"	"A"	"B"	"C"	"D"	NO. OF WIRES	ULTIMATE RATING (PER WIRE)
CTA22G096N4003B	003	96"	15"	N/A	44"	42"	4	2,250 LBS
CTA22G096N6004B	004	96"	15"	29.5"	44"	42"	6	1,500 LBS
CTA22G120N4007B	N/A	120"	19"	N/A	56"	54"	4	2,250 LBS
CTA22G120N6005B	005	120"	19"	37.5"	56"	54"	6	1,500 LBS

Smart Part Numbering System

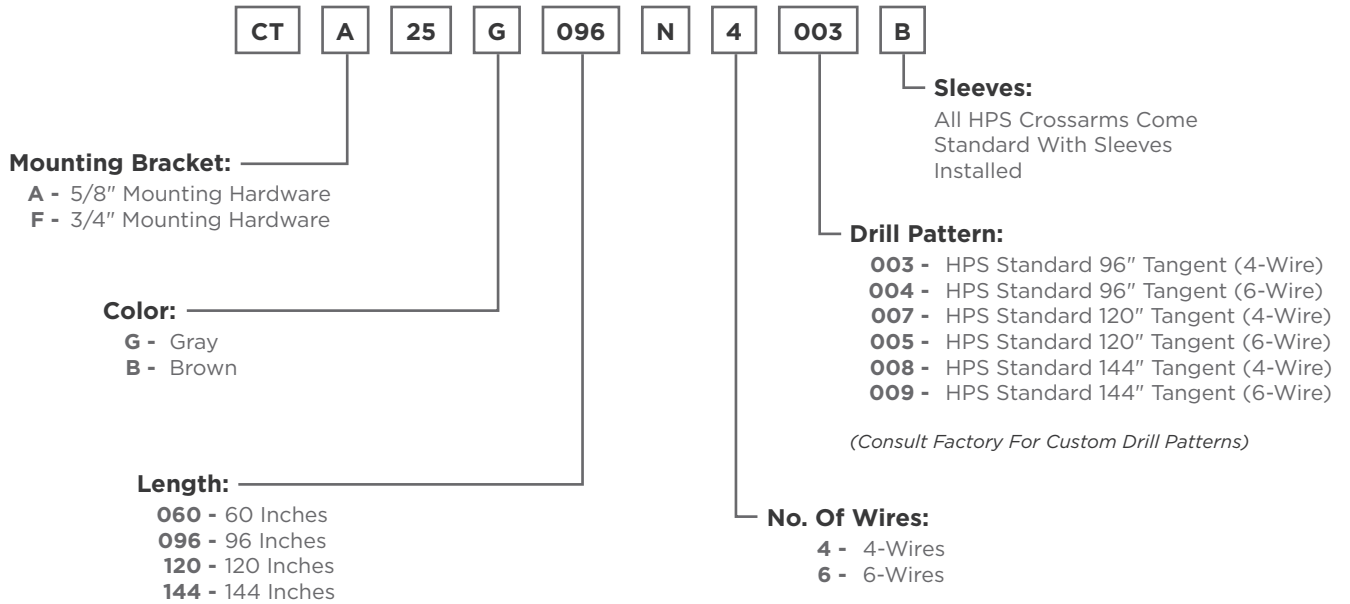

Series 25 Tangent

Catalog Number	Length	No. of Wires	Minimum Ultimate Longitudinal Load per wire	Mounting Bracket Hardware	Total Assembly Weight (Each)	Color	Drill Pattern
CTA25G096N4003B	96" (8')	4	3,500 lbs.	5/8"	55 lbs.	Gray	003
CTA25G096N6004B	96" (8')	6	2,250 lbs.	5/8"	55 lbs.	Gray	004
CTA25G120N4007B	120" (10')	4	3,500 lbs.	5/8"	63 lbs.	Gray	007
CTA25G120N6005B	120" (10')	6	2,250 lbs.	5/8"	63 lbs.	Gray	005
CTA25G144N4008B	144" (12')	4	3,500 lbs.	5/8"	71 lbs.	Gray	008
CTA25G144N6009B	144" (12')	6	2,250 lbs.	5/8"	71 lbs.	Gray	009

Fiberglass Series 25 Tangent

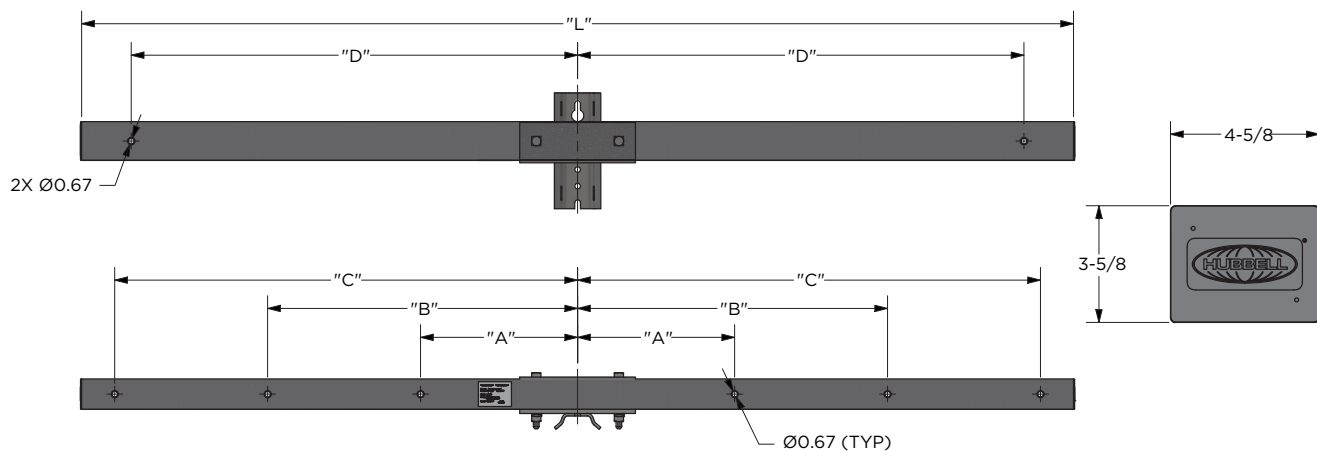

1. **MATERIAL: Arm:** Fiberglass tube filled with closed cell foam mounting bracket & **Hardware:** Galvanized steel
2. **COLOR:** Gray (brown optional) painted with UV inhibitor paint
3. All crossarm holes come standard with sleeves installed
4. **RECOMMENDED HARDWARE TORQUE:** 250 in-lbs
5. **HOLES AVAILABLE IN OPTIONAL SIZES DEPENDING ON CATALOG NUMBER:**
 "CDA": 5/8" hardware
 "CDF": 3/4" hardware
6. For a complete list of options see Smart Numbering System

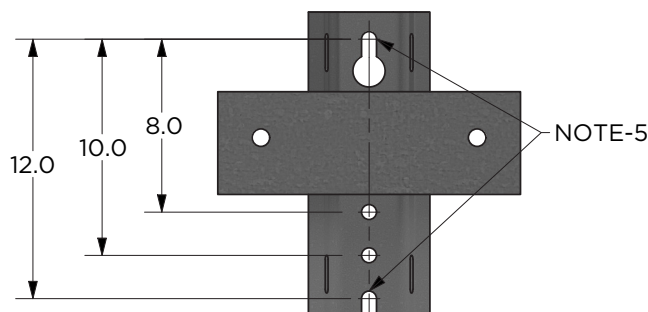

Catalog Number (Note 8)	RUS DRILL PATTERN	"L"	"A"	"B"	"C"	"D"	NO. OF WIRES	ULTIMATE RATING (PER WIRE)
CTA25G096N4003B	003	96"	15"	N/A	44"	42"	4	3,500 LBS
CTA25G096N6004B	004	96"	15"	29.5"	44"	42"	6	2,250 LBS
CTA25G120N4007B	N/A	120"	19"	N/A	56"	54"	4	3,500 LBS
CTA25G120N6005B	005	120"	19"	37.5"	56"	54"	6	2,250 LBS
CTA25G144N4008B	N/A	144"	38"	N/A	66"	68"	4	3,500 LBS
CTA25G144N6009B	N/A	144"	38"	53"	66"	68"	6	2,250 LBS

Smart Part Numbering System

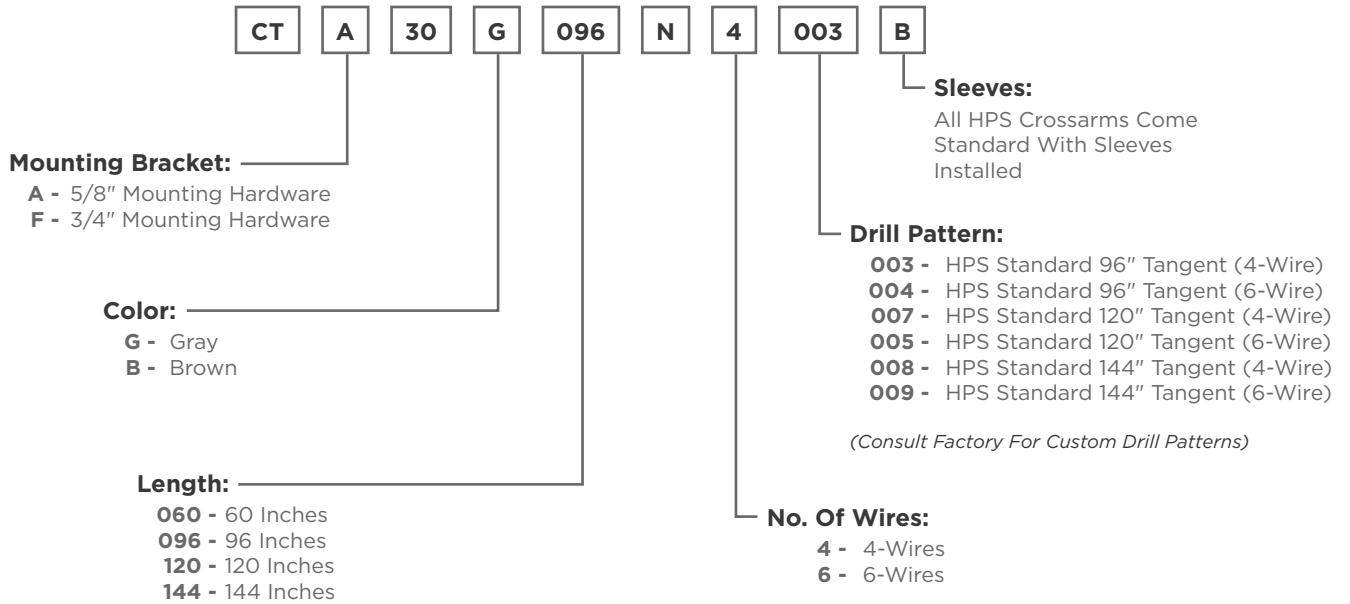

Series 30 Tangent

Catalog Number	Length	No. of Wires	Minimum Ultimate Longitudinal Load per wire	Mounting Bracket Hardware	Total Assembly Weight (Each)	Color	Drill Pattern
CTA30G096N4003B	96" (8')	4	5,000 lbs.	5/8"	67 lbs.	Gray	003
CTA30G096N6004B	96" (8')	6	3,250 lbs.	5/8"	67 lbs.	Gray	004
CTA30G120N4007B	120" (10')	4	5,000 lbs.	5/8"	78 lbs.	Gray	007
CTA30G120N6005B	120" (10')	6	3,250 lbs.	5/8"	78 lbs.	Gray	005
CTA30G144N4008B	144" (12')	4	5,000 lbs.	5/8"	89 lbs.	Gray	008
CTA30G144N6009B	144" (12')	6	3,250 lbs.	5/8"	89 lbs.	Gray	009

Fiberglass Series 30 Tangent

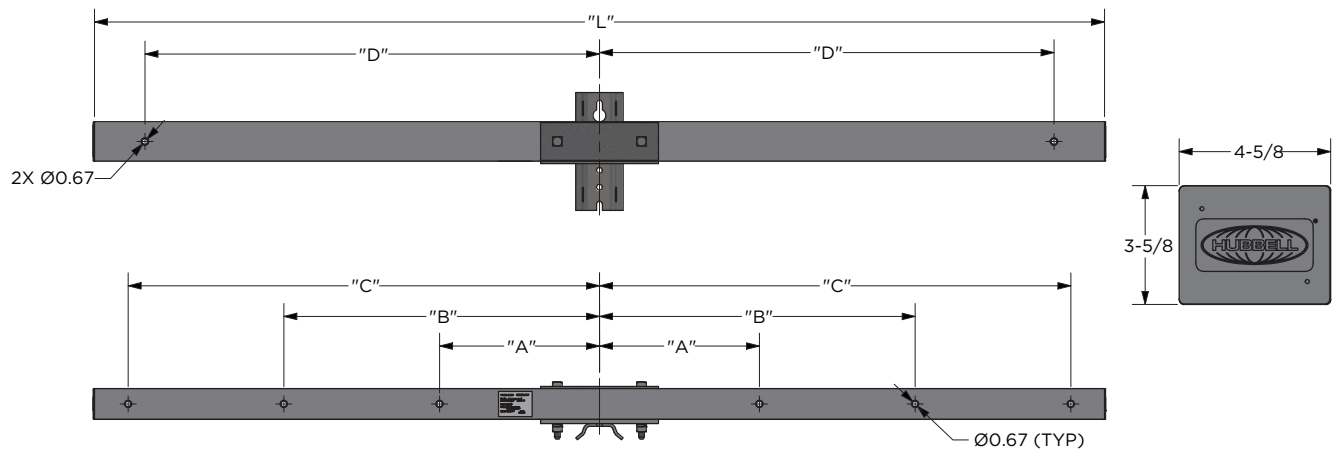

- MATERIAL: Arm:** Fiberglass tube filled with closed cell foam mounting bracket & **Hardware:** Galvanized steel
- COLOR:** Gray (brown optional) painted with UV inhibitor paint
- All crossarm holes come standard with sleeves installed
- RECOMMENDED HARDWARE TORQUE:** 250 in-lbs
- HOLES AVAILABLE IN OPTIONAL SIZES DEPENDING ON CATALOG NUMBER:**
 "CDA": 5/8" hardware
 "CDF": 3/4" hardware
- For a complete list of options see Smart Numbering System

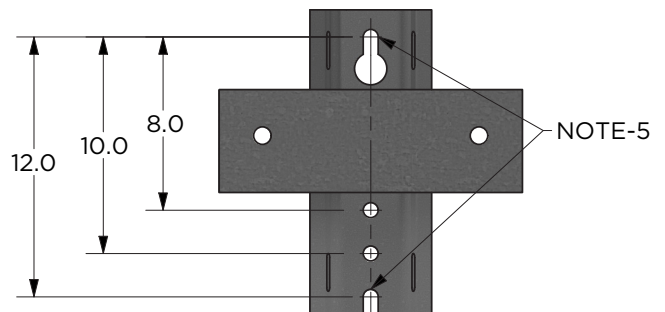

Catalog Number (Note 8)	RUS DRILL PATTERN	"L"	"A"	"B"	"C"	"D"	NO. OF WIRES	ULTIMATE RATING (PER WIRE)
CTA30G096N4003B	003	96"	15"	N/A	44"	42"	4	5,000 LBS
CTA30G096N6004B	004	96"	15"	29.5"	44"	42"	6	3,250 LBS
CTA30G120N4007B	N/A	120"	19"	N/A	56"	54"	4	5,000 LBS
CTA30G120N6005B	005	120"	19"	37.5"	56"	54"	6	3,250 LBS
CTA30G144N4008B	N/A	144"	38"	N/A	66"	68"	4	5,000 LBS
CTA30G144N4009B	N/A	144"	38"	53"	66"	68"	6	3,250 LBS

Hubbell crossarms come pre-drilled with standard or custom drill patterns of your choice for easy installation. Each drill hole is sleeved with an insert to offer torque protection when installing hardware. See part numbering system for a list of standard drill patterns or consult customer service for customs.

Field drilling is also acceptable as needed.

Suggestions for field drilling:

- Use a carbide tip bit
- Measure hole spacing at least 4" from outer edge, drill slowly and straight
- Recommended hardware torque: 250 IN-LBS
- Consider using washers that extend the width of the arm (4"x4") to offer additional support
- Press fit sleeves for added crushing protection are available upon request, however they are not necessary due to the moisture protection our closed cell foam offers

Related Products

Part Number	Description
6502	Standard 5/8 Eyenut
6503	Standard 3/4 Eyenut
8812 or 8814	Machine Bolt,Sq Head, 5/8" x 12"or 14"
8912 or 8914	Machine Bolt,Sq Head, 3/4" x 12"or 14"
PSC2050828	4in square flat washer for 5/8" bolt size, 11/16" hole
6818	4in square flat washer for 3/4" bolt size, 13/16" hole
GCW31	3in square curved cast washer for 5/8" bolt size, 11/16" hole
GCW31A	3in square curved cast washer for 5/8" bolt size, 11/16" hole
PSS18265P	Gray touch up paint

